



GPO Box 530, DARWIN NT 0801
 Phone: 1300 654 628
 Fax: (08) 8999 3103
 Email: nt.wovr@nt.gov.au
 Website: www.nt.gov.au

Official Use Only		
Processed by -	User ID -	Date -/...../.....
Comments:		

VS7

PLEASE READ IMPORTANT NOTICE ON PAGE 3

Written-off Vehicle Advice

Owner Details	
Surname/Company Name	Given Name/s
Postal Address	Residential Address
Postcode	Postcode

Vehicle Details														
Registration Plate	Make	Model												
Date of Manufacture	VIN / Chassis Number													
Body Type / Vehicle Type (please tick one only) <table style="width: 100%; margin-top: 5px;"> <tr> <td><input type="checkbox"/> Car</td> <td><input type="checkbox"/> Motorcycle</td> <td><input type="checkbox"/> Rigid Truck</td> <td><input type="checkbox"/> Prime Mover</td> <td><input type="checkbox"/> Trailer (> 4.5t ATM Only)</td> <td><input type="checkbox"/> Caravan (> 4.5t ATM Only)</td> </tr> <tr> <td><input type="checkbox"/> Ute</td> <td><input type="checkbox"/> Sedan</td> <td><input type="checkbox"/> Coupe</td> <td><input type="checkbox"/> S/Wagon</td> <td colspan="2"><input type="checkbox"/> Other</td> </tr> </table>			<input type="checkbox"/> Car	<input type="checkbox"/> Motorcycle	<input type="checkbox"/> Rigid Truck	<input type="checkbox"/> Prime Mover	<input type="checkbox"/> Trailer (> 4.5t ATM Only)	<input type="checkbox"/> Caravan (> 4.5t ATM Only)	<input type="checkbox"/> Ute	<input type="checkbox"/> Sedan	<input type="checkbox"/> Coupe	<input type="checkbox"/> S/Wagon	<input type="checkbox"/> Other	
<input type="checkbox"/> Car	<input type="checkbox"/> Motorcycle	<input type="checkbox"/> Rigid Truck	<input type="checkbox"/> Prime Mover	<input type="checkbox"/> Trailer (> 4.5t ATM Only)	<input type="checkbox"/> Caravan (> 4.5t ATM Only)									
<input type="checkbox"/> Ute	<input type="checkbox"/> Sedan	<input type="checkbox"/> Coupe	<input type="checkbox"/> S/Wagon	<input type="checkbox"/> Other										

Incident Details / NEVDIS WOV R Restriction Type			
Date of Incident	/ /	NEVDIS WOV R Restriction Type (please tick one only)	
Date of Assessment	/ /	<input type="checkbox"/> Collision (C)	<input type="checkbox"/> Storm, Flood, Other (W)
<input type="checkbox"/> Fire Damage	<input type="checkbox"/> Impact Damage	<input type="checkbox"/> Unrecovered	<input type="checkbox"/> Vandalism (Major or Minor)
<input type="checkbox"/> Hail Damage	<input type="checkbox"/> Stripping	<input type="checkbox"/> Water (Salt or Fresh)	<input type="checkbox"/> Other
(MUST SPECIFY & REFER WOV R ADMIN)			

Damage Locations and Severity Codes (refer to Page 2)

Salvage Condition (refer to the National Assessment Guidelines for the Determining a Write-Off on Page 2 when assessing all damaged vehicles)

Repairable Write-off
 Statutory Write-off*
 Unrecovered

*For a Statutory write-off, applicant to ensure that the VIN and Compliance Plate (or Compliance Label) is to be rendered null and void (i.e. VIN and compliance plate marked with a diagonal chisel line; compliance label removed and destroyed)

Details of Person Making Declaration						
Surname/Company Name	Given Name/s	Contact Phone Number				
What authority do you have to complete this form? (Please select one and complete any details) <table style="width: 100%; margin-top: 5px;"> <tr> <td><input type="checkbox"/> Registered Owner - Customer Identification Number <i>(You can obtain your Customer ID from MVR)</i></td> <td><input type="checkbox"/> Insurance Assessor <i>(Name of Insurance Company)</i></td> </tr> <tr> <td><input type="checkbox"/> Motor Trader <i>(Business Name and Trader's Licence Number)</i></td> <td><input type="checkbox"/> Approved or Suitably Qualified Persons <i>(Authorised to assess damaged vehicles and Approval Number)</i></td> </tr> </table>			<input type="checkbox"/> Registered Owner - Customer Identification Number <i>(You can obtain your Customer ID from MVR)</i>	<input type="checkbox"/> Insurance Assessor <i>(Name of Insurance Company)</i>	<input type="checkbox"/> Motor Trader <i>(Business Name and Trader's Licence Number)</i>	<input type="checkbox"/> Approved or Suitably Qualified Persons <i>(Authorised to assess damaged vehicles and Approval Number)</i>
<input type="checkbox"/> Registered Owner - Customer Identification Number <i>(You can obtain your Customer ID from MVR)</i>	<input type="checkbox"/> Insurance Assessor <i>(Name of Insurance Company)</i>					
<input type="checkbox"/> Motor Trader <i>(Business Name and Trader's Licence Number)</i>	<input type="checkbox"/> Approved or Suitably Qualified Persons <i>(Authorised to assess damaged vehicles and Approval Number)</i>					

Declaration **Warning:** Persons who by false statement or misrepresentation, obtain or attempt to obtain benefit from this Written-off Vehicle Advice are liable to a fine not exceeding 15 Penalty Units for an Individual (85 Penalty Units for a Company) or imprisonment for 6 months under the *Motor Vehicles Act*.

I, of
(Name) (Address)
 declare that the information provided in this advice is true and correct.

.....
(Signature) (Date)

Privacy Statement
 The Registrar of Motor Vehicles is required to collect information under the *Motor Vehicles Act*. The Registrar adheres to the Department's Privacy Statement and the *Information Act*. Further information on privacy can be found at www.transport.nt.gov.au/mvr/about-us

National Assessment Guidelines for the Determining a Write-Off

All damaged vehicles that are assessed as being a Total Loss as per the definition below must be assessed using the Damage Assessment Criteria for the Classification of Statutory Write-Offs, published by the National Motor Vehicle Theft Reduction Council to determine if the vehicle is a Statutory or Repairable Write-Off.

The Damage Assessment Criteria for the Classification of Statutory Write-Offs, are available on the National Motor Vehicle Theft Reduction Council website at: <http://www.carsafe.com.au/stakeholders-a-partners/publications/management-of-written-off-vehicles>

A vehicle or trailer that is assessed as a Total Loss and is not a Statutory Write-off.

A vehicle that has sustained extensive damage to major vehicle components, has been assessed as a Total Loss and meets the Statutory Write-Off criteria as detailed in the Damage Assessment Criteria for the Classification of Statutory Write-Offs, as published by the National Motor Vehicle Theft Reduction Council.

Note: "Total Loss" means a motor vehicle or trailer damaged by collision, fire, flood, accident, trespass, dismantling, demolition or other event to the extent that its fair salvage value plus the cost of repairing the vehicle for use on a road or road related area would be more than the fair market value of the vehicle immediately before the event that caused the damage.

Damage Location Codes

1	Left Front	11	Rear	21	Chassis/Structural Rails (right)	31	Transmission Case
2	Right Front	12	Rear Left	22	A Pillar (left)	32	Differential Case
3	Right Side	13	Rear Right	23	A Pillar (right)	33	Axle Housing
4	Right Side Rear	14	Whole Vehicle	24	B Pillar (left)	34	Suspension (left front)
5	Left Side Rear	15	Floor Pan (left front)	25	B Pillar (right)	35	Suspension (right front)
6	Left Side	16	Fire Wall	26	C Pillar (left)	36	Suspension (left rear)
7	Engine	17	Chassis/Structural Rails (left)	27	C Pillar (right)	37	Suspension (right rear)
8	Roof	18	Floor Pan (right rear)	28	D Pillar (left)	38	Airbag (front)
9	Interior	19	Floor Pan (right front)	29	D Pillar (right)	39	Airbag (side)
10	Front	20	Floor Pan (left rear)	30	Engine Block (cracked, fractured)	40	Airbag (curtain)
						41	Seatbelt Pre-tensioner

Damage Severity Codes

A	Heavy Panel	E	Unrepairable	I	Minor Stripping	M	Water (fresh)
B	Light Panel	F	Major Mechanical Damage	J	Major Vandalism	N	Burnt/Blistered
C	Heavy Structural	G	Minor Mechanical Damage	K	Minor Vandalism	O	Smoke and Heat
D	Light Structural	H	Major Stripping	L	Water (salt)	P	Minor Smoke

Location Severity Codes

1st Incident Type	Damage Location	1	2	3	4	5	6	7	8	9	10	11	12	13	14
	Damage Severity														
	Damage Location	15	16	17	18	19	20	21	22	23	24	25	26	27	28
	Damage Severity														
	Damage Location	29	30	31	32	33	34	35	36	37	38	39	40	41	
	Damage Severity														

2nd Incident Type	Damage Location	1	2	3	4	5	6	7	8	9	10	11	12	13	14
	Damage Severity														
	Damage Location	15	16	17	18	19	20	21	22	23	24	25	26	27	28
	Damage Severity														
	Damage Location	29	30	31	32	33	34	35	36	37	38	39	40	41	
	Damage Severity														

Location and Severity of Damage Guide

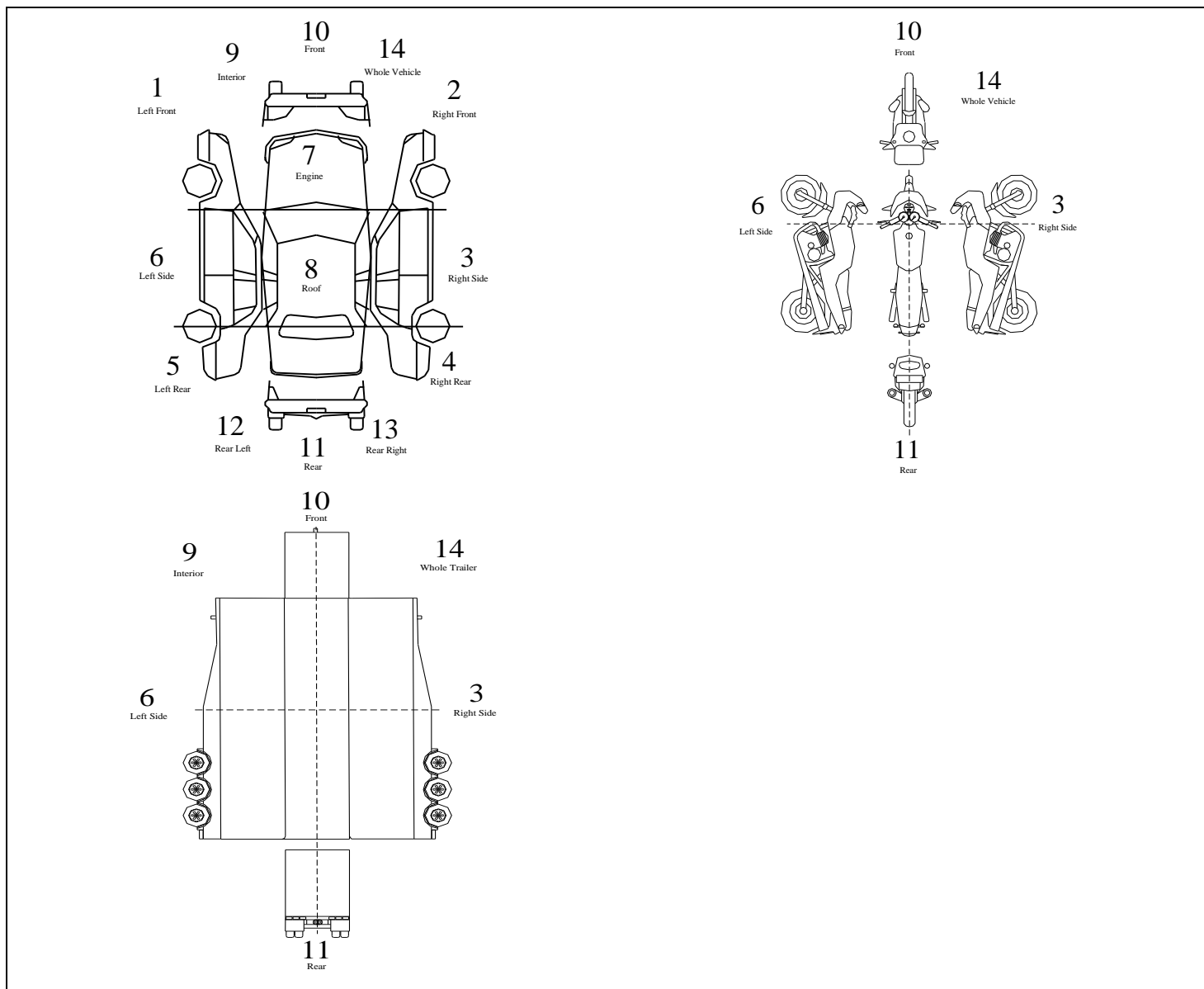

Important Notice

The information you give us by filling in this form is being collected for the purpose of compliance with and enforcement of the *Motor Vehicles Act* (NT). The Registrar of Motor Vehicles is required to collect this information by Regulation 18 of the Motor Vehicle Regulations. It is the usual practice of the Registrar to disclose to the parties listed here some or all the information given by you on this form where those parties have satisfied certain conditions to the disclosure. By signing this form you consent to the disclosure of that information.

Personal Information provided on this form is collected in accordance with the provisions of the *Traffic Act* and *Motor Vehicles Act*. The Department adheres to the provisions of the privacy legislation contained within the *Information Act* (NT). Further information on privacy can be found at www.transport.nt.gov.au

The information you give us by filling in this form may be disclosed to another person, body or agency (including governments of the States and Territories and their agencies, local and municipal councils) in the following circumstances:

- (i) where we believe on reasonable grounds that the disclosure is necessary to prevent or lessen a serious and imminent threat to the life or health of you or another person;
- (ii) if the disclosure is required or authorised by or under law;
- (iii) the disclosure is reasonably necessary for the enforcement of criminal law or a law imposing a monetary penalty or for the protection of the public revenue.

Note:

This vehicle has been deemed to be a write off. A statutory write-off cannot be re-registered. A repairable write-off will require a level 2 inspection before it can be re-registered.

Please be advised that this vehicle registration will be cancelled by the MVR on the receipt of this form.