

Critical control points

Information sheet – Recycled water

Background

Recycled water treatment must control hazards which represent a risk to human health or the environment. The control of these hazards must be measurable to ensure risk is reduced to an acceptable level.

A critical control point (CCP) is an activity, procedure or process where control can be applied and which is critical to controlling hazards that represent high risks to acceptable levels.

Identification of a CCP considers the hazards present in a particular system. Hazards that represent a high risk should be controlled at one or more CCP; one CCP can control more than one hazard. Several criteria are used to identify critical control points:

- The controls employed for the CCP (e.g. kill/inactivation of pathogens by chlorination) can significantly reduce the risk posed by a hazard or hazards.
- The operational parameters for the CCP have defined critical limits which can be measured.
- Breaching critical limits of operational parameters at the CCP poses a significant risk and necessitates immediate corrective action or cessation of supply.
- The operational parameters at the CCP are monitored at a frequency sufficient to identify failures and respond in a timely manner.
- An action (correction) can be undertaken in response to a deviation from normal operational parameters.

Hazards are not considered to be controlled unless the operation of the control can be measured with adequate timeliness.

Common critical control points in recycled water treatment are given in Box 1.

Box 1: Common critical control points

- Secondary treatment processes
- Membrane filtration
- Chlorination
- UV disinfection
- Lagoon retention
- Reservoir detention (dual reticulation)

Figure 2.2 in the Australian Guidelines for Water Recycling (AGWR, 2006) provides a flow sheet describing how to identify a critical control point.

The acronym “SMART” can be used to help decide if a process can be classified as a CCP (shown in Box 2).

Box 2 Determination of CCPs

S	Significant risk
M	Measurable
A	Action
R	Reduce risk
T	Timely manner

Significant - Is there a significant risk managed by the process?

Measurable - Can the process be measured and limits established where action needs to be taken?

Action - Are there actions that can be implemented if the process is measured to be outside acceptable limits?

Reduce - Will these actions reduce the risk?

Timely - Can the measurements and response actions be carried out in a timely manner?

Monitoring CCPs

Operational parameter(s) are used to measure the effectiveness of a CCP in controlling a hazard. Figure 1 is a treatment schematic showing common CCPs and operational parameters.

The operational parameter may be a surrogate for the hazard being controlled e.g. free chlorine residual for a bacterial hazard. The monitoring point may be at a different location to the CCP. For example, the turbidity meter monitoring effectiveness of a microfiltration plant may be located at the inlet to a downstream UV unit.

Target criteria

Target criteria should be set for each operational parameter of a CCP. Maintaining the process within the target criteria is often achieved by continual optimisation and improvement.

Adjustment limits

Adjustment limits assist recycled water suppliers establish when action is required to maintain system control before the critical limit is breached.

Critical limits

The critical limit is the value outside of which the CCP is no longer adequately controlling the hazard and operational corrections or emergency procedures must be instituted immediately. The critical limit should reflect the operating limits associated with the treatment process validation.

See Information sheet: *Validation & Verification- What's the difference?* for more details.

CCP Procedures

Every CCP should have a one-page procedure document prominently displayed at the relevant point of operation showing the key aspects of the CCP. This includes:

CCP description

- What are the hazards?
- What is being measured?
- Where/how is it measured?
- How is it controlled?

Limits

- Target Criteria
- Adjustment Limits
- Critical limit(s).

Actions

Actions to be undertaken when the plant is operating:

- Within the target criteria (normal operating procedures)
- Within the adjustment limits (corrections)
- At or beyond the critical limits (corrections or emergency procedures). The actions should include appropriate notification, e.g. to the DoH Public Health Directorate.

Figure 1 Example of a schematic showing CCPs & operational parameters

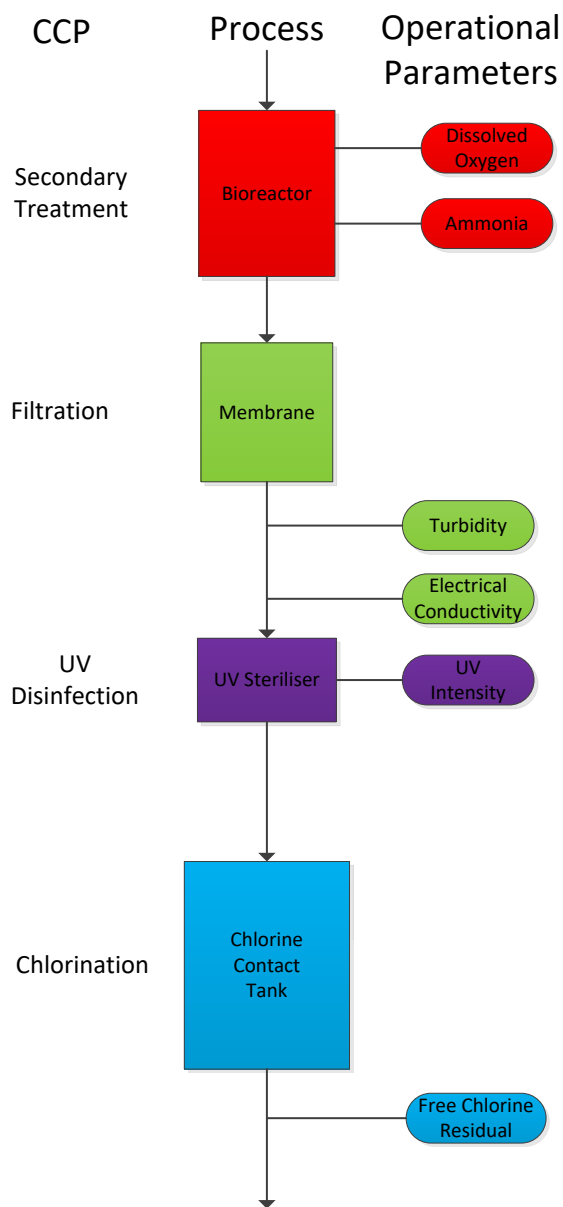

References

Australian Guidelines for Water Recycling (2006)

For more information

Contact Department of Health – Public Health Directorate by calling (08) 8922 7152 or email wastewater@nt.gov.au

This information was adapted from the Recycled Water Information Sheet series © Department of Primary Industries, New South Wales Government.