

Motor Vehicle Registry Information Bulletin

V13 Vehicle Dimensional Limits (Including Load)

Introduction

Maximum vehicle dimension limits in the Northern Territory (NT) are nationally consistent and are set out in the *NT Motor Vehicle (Standards) Regulations* which incorporate the *Australian Vehicle Standards Rules*. These vehicle dimension limits **include any load placed on a vehicle**.

All vehicles travelling on the road network in the NT must comply with the maximum dimensional limits unless the vehicle is carrying a permit of exemption issued by the Registrar of Motor Vehicles.

Permits of exemption may be issued in special cases for vehicles carrying indivisible loads or for non-complying vehicles that, by design, exceed dimensional limits. Permits will generally have conditions of operation on the vehicle (i.e. route restrictions) to enable it to safely travel on the road network.

Width and Height

The overall maximum width of a vehicle - including any load on the vehicle - is not to exceed 2.5m.

This excludes lights, mirrors, reflectors, central tyre inflation systems and signalling devices.

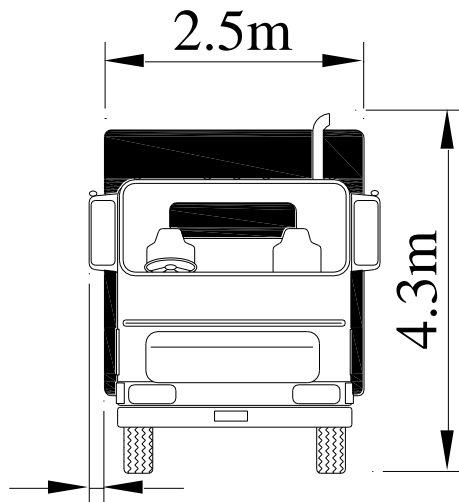

Note:

- 1 Vehicles with a GVM over 3.5t may have mirrors that project up to 230mm beyond the widest part of the vehicle providing they can fold down to 150mm.
- 2 Maximum vehicle height including any load is 4.3m.
- 3 Vehicles designed and built to carry livestock may be up to 4.6m.
- 4 Vehicles designed and built to carry motor vehicles, on more than 1 deck, may be loaded up to 4.6m.
- 5 Double-deck buses may be up to 4.4m.

Projecting Loads and Equipment

Loads and equipment carried on vehicles may project to the front, rear and sides of a vehicle providing the projection does not exceed the maximum dimensions shown below.

Any projection must be contained within the maximum overall vehicle dimensional limits (i.e. must not exceed maximum vehicle overall length or width).

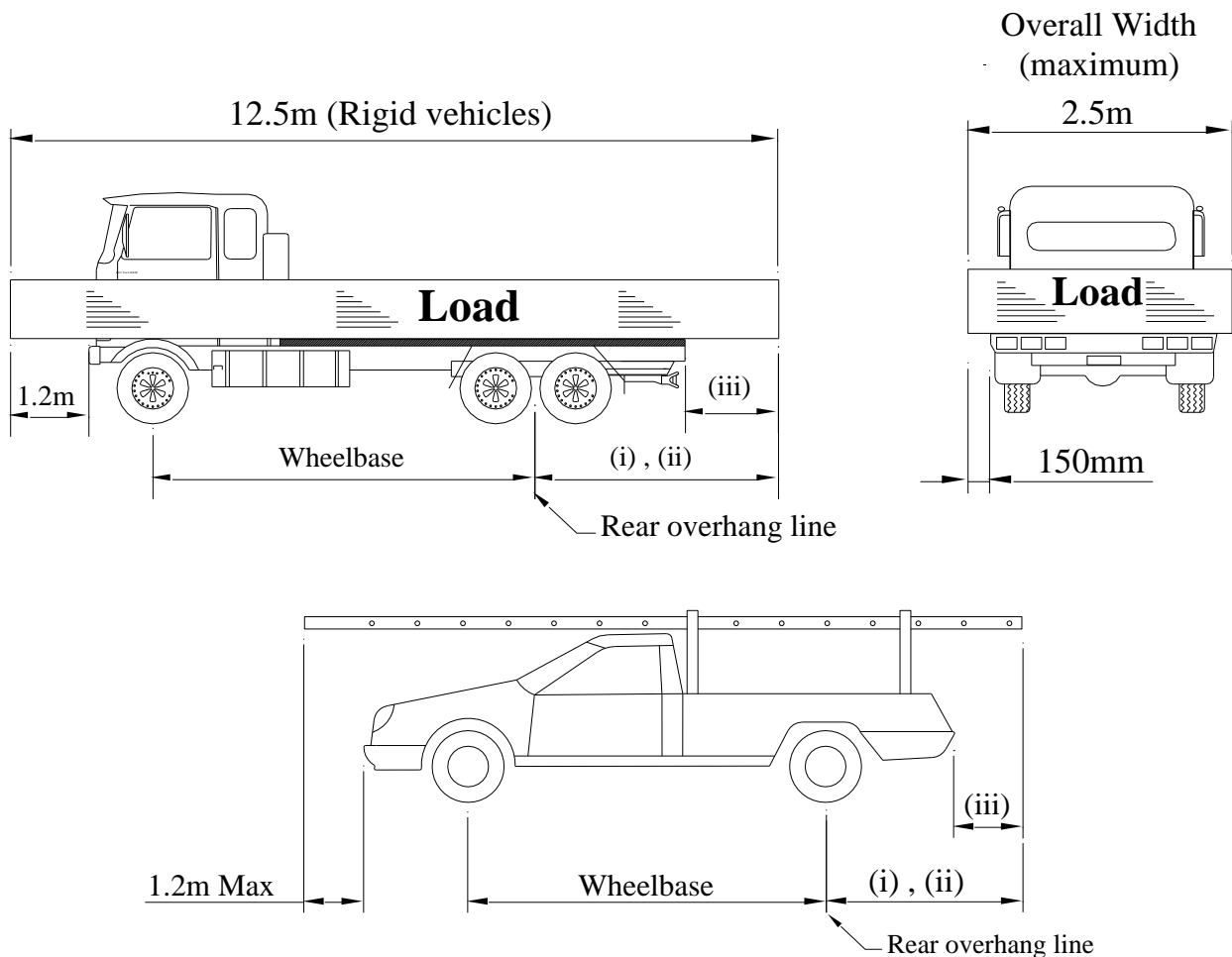

- (i) Rear overhang is measured from the centre of the rear axle or axle group to the extreme rear of the vehicle including any load on the vehicle.
- (ii) Rear overhang must not exceed the lesser of 60% of the wheelbase or 3.7m. Rear overhang on loaded car carrier trailers, carrying vehicles on more than one deck, may be up to 4.9m, and is measured from the rear overhang line to the rear of the rearmost vehicle carried on the trailer.
- (iii) Projecting load to the rear - if a load projects more than 1.2m from the rear of a vehicle, it must carry a warning signal attached to the rear of the load.

In daylight, a warning signal is a brightly coloured flag with sides at least 300mm long.

At night, a warning signal is a red light that can be seen from a distance of at least 200m.

Note:

- 1 A load on a vehicle is not to project in a way that is dangerous to a person or to property, even if all dimension and warning requirements, as detailed above, are met.
- 2 Any projection must be contained within the maximum overall width of 2.5m.

Length

The following diagrams show the maximum vehicle length for various vehicles and vehicle combinations.

All maximum length dimensions include any load carried on the vehicle.

Rigid Vehicles

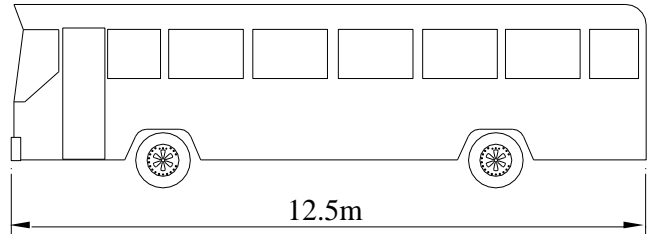
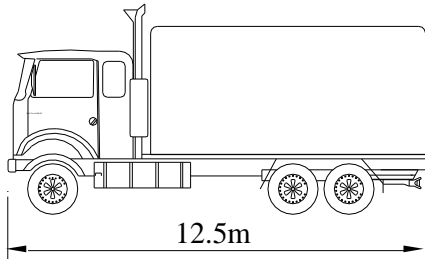

Note: Controlled Access Bus may be up to 14.5m

Articulated Bus

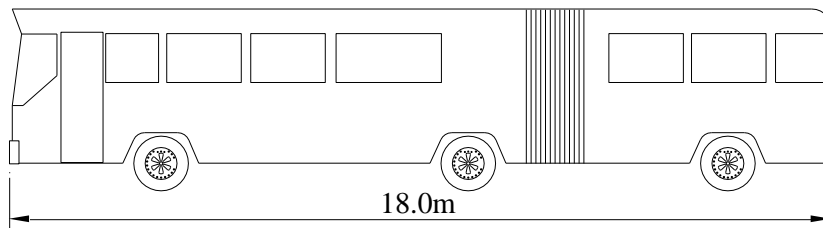

Articulated Vehicle

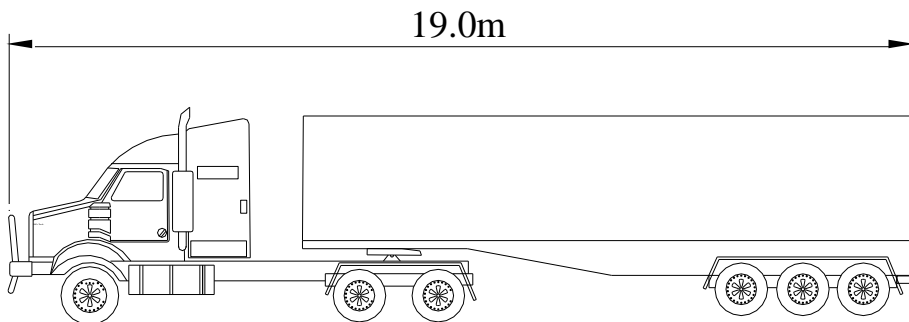

Truck and Dog Trailer

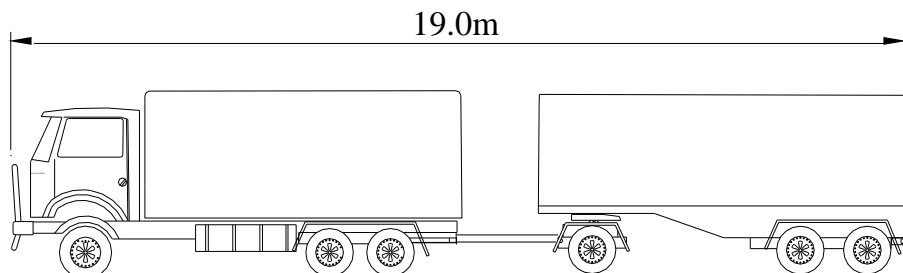

Truck and Pig Trailer

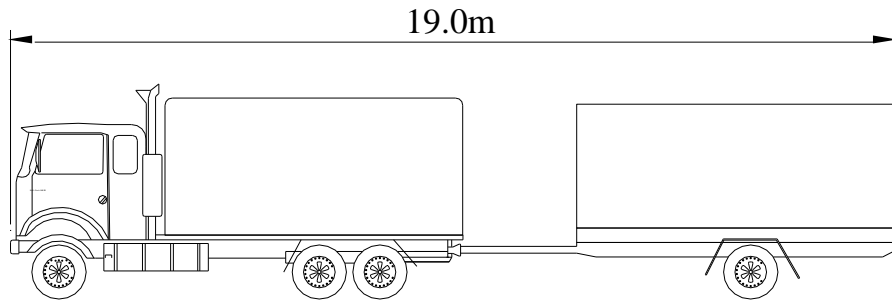

B-Double

Definition: A combination consisting of a prime mover towing two semi-trailers.

Note: For livestock the two trailers must not have more than 18.8m of their combined length available for the carriage of animals.

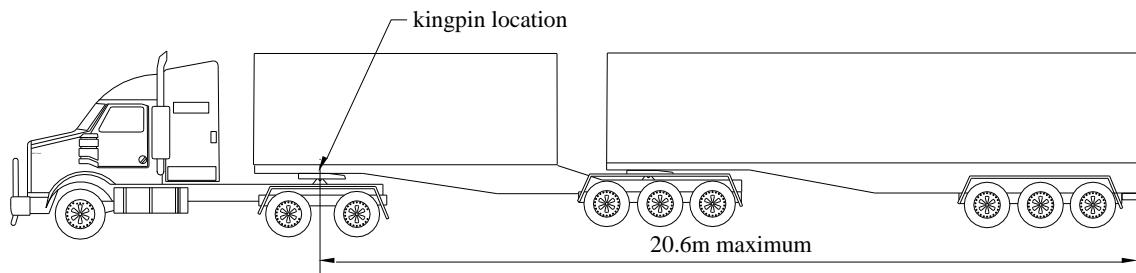

Road Train

Definition: A combination consisting of a prime mover or rigid vehicle towing at least two trailers that is not a B-Double (a converter dolly supporting a semi trailer is deemed to be a single trailer).

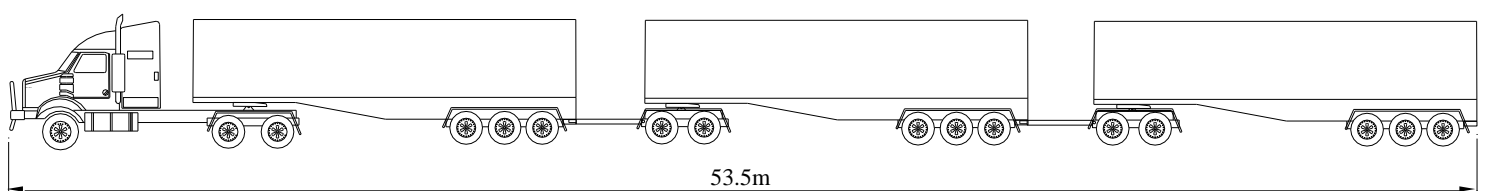
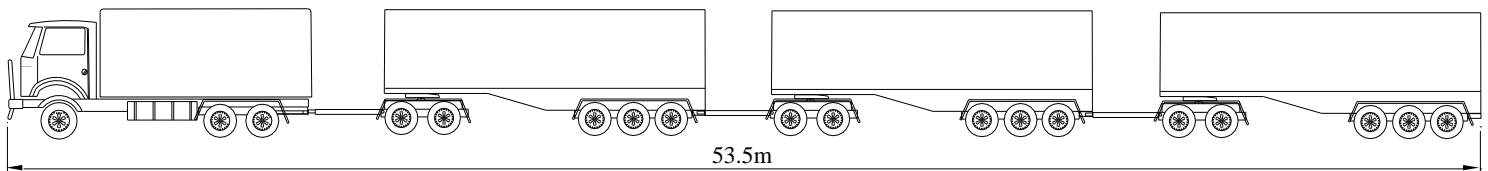

Car Carrier

Definition: A vehicle combination - not being a road train - designed to carry vehicles on two or more partly or completely overlapping decks.

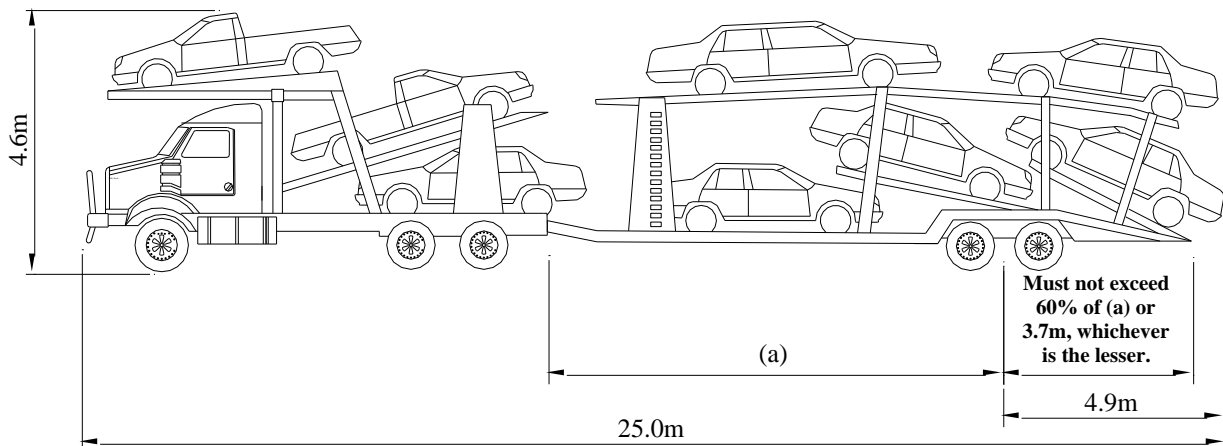

Pig Trailer

Definition: A trailer with one axle group or single axle near the middle of its load carrying surface, and connected to the towing vehicle by a drawbar.

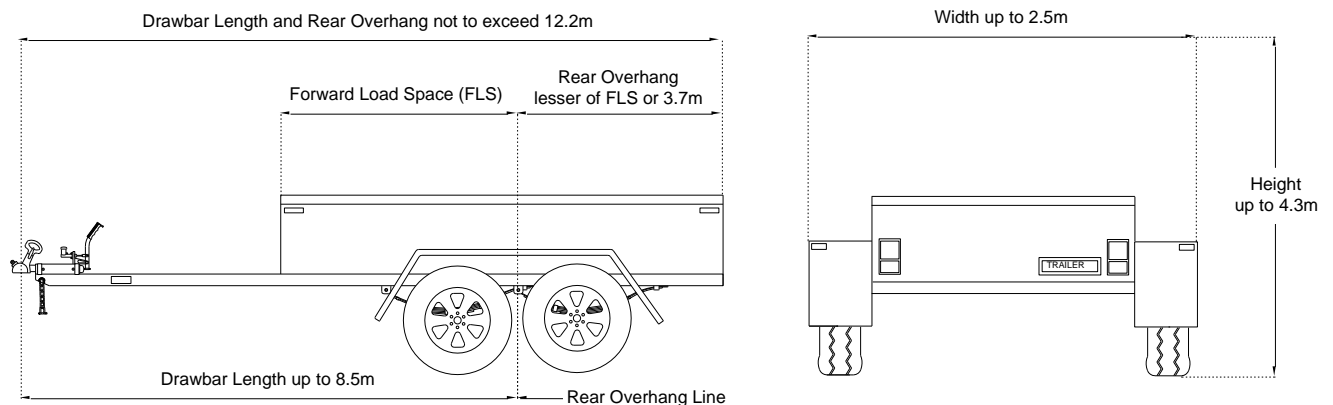

Note:

- 1 Rear Overhang must not exceed Forward Load Space (FLS) or 3.7m – whichever is the lesser.
- 2 Drawbar length, Forward Load Space (FLS) and Rear Overhang must be measured from the rear overhang line.
- 3 Drawbar length is measured from the point of articulation on the tow coupling.
- 4 Overall length, including load and equipment, not to exceed 12.5m

Semi Trailer

Definition: A trailer that has:

- (a) 1 axle group or single axle to the rear; and
- (b) a means of attachment to a prime mover that results in some of the load being imposed on the prime mover.

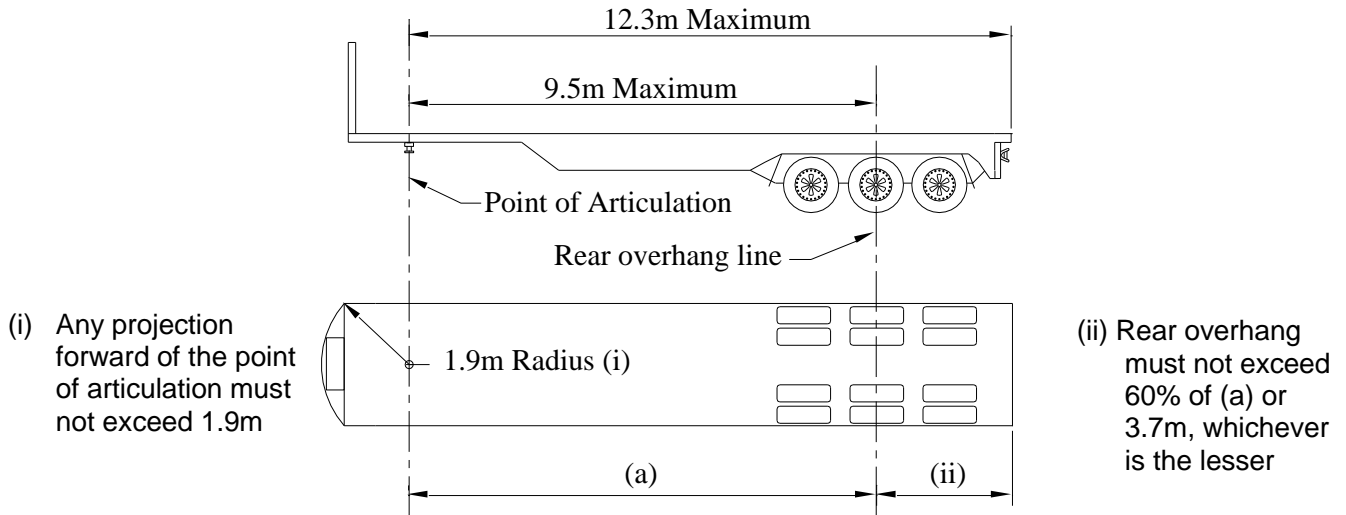

Dog Trailer

Definition: A trailer (including a trailer consisting of a semi trailer and converter dolly) that has:

- (a) one axle group or single axle at the front that is steered by connection to the towing vehicle by a draw bar; and
- (b) one axle group or single axle at the rear.

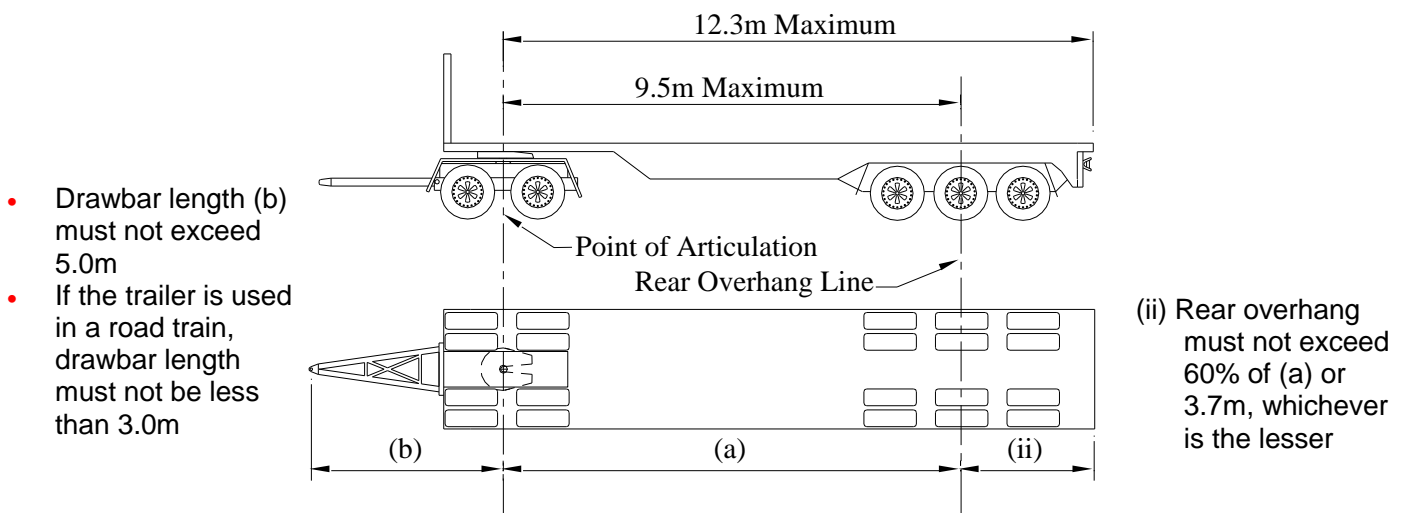

Contact Details	
Motor Vehicle Registry	
Telephone	1300 654 628
Facsimile	(08) 8999 3103
Email	mvr@nt.gov.au
Web	www.mvr.nt.gov.au
Postal Address	GPO Box 530 Darwin NT 0801