

Application to Modify a Light Vehicle (not more than 4.5t GVM)

Fields marked with asterisk (*) are mandatory VS32(lv)

<i>Office use only</i> [^]	Vehicle Id [^]		File Reference [^]		Date received [^]	
-------------------------------------	-------------------------	--	-----------------------------	--	----------------------------	--

Section 1 - Owner/Applicant details

Owner/Applicant*	NT Residence (✓) Yes <input type="checkbox"/> No <input type="checkbox"/>
------------------	--

Address*

Postal address*

Contact Person*
(including authorised representative, where applicable)

Name	Phone*	Email*
------	--------	--------

Notes for guidance

- (1) This application form should be read in conjunction with Information Bulletin V32(lv) – Light Vehicle Modifications
- (2) NT vehicle modification scheme is only available to vehicle owners/operators who meet NT residency requirements for vehicle registration
- (3) Please attach any drawings, sketches, engineering approvals, kit approvals, photographs or any other information that you consider will assist in assessing this application. The more information you supply with this application, the less likelihood of delays
- (4) Applicants should NOT commence work until they receive written approval in principle to proceed with modifications
- (5) "tick" the appropriate box as required
- (6) Where an agent/contact person is the representative of the vehicle owner, written authorisation of authority is required from the owner
- (7) Modern production vehicles approved for use in Australia will be issued a Commonwealth vehicle approval number known as an Identification Plate Approval (IPA) or Compliance Plate Approval (CPA) or Vehicle Type Approval (VTA). This number is required in Section 2, if known

Type of modification - tick categories that apply to this application

Street Rod <input type="checkbox"/>	Individually Constructed Vehicle <input type="checkbox"/>	Motorhome/Campervan <input type="checkbox"/>	Commercial Passenger Vehicle <input type="checkbox"/>
Imported Vehicle <input type="checkbox"/>	Driver Training/Adaptive System Controls <input type="checkbox"/>	Wheelchair Accessible <input type="checkbox"/>	Production Vehicle <input type="checkbox"/>

Section 2 - Vehicle details

Registration Plate Number*	State*	Yes <input type="checkbox"/> No <input type="checkbox"/>	CPA/VTA*
Make*	Model*	Vehicle Identification/Chassis/Serial Number*	
Body Style*	Date of Manufacture*(mm/yyyy)	Gross Vehicle Mass	Braked Towing Capacity
Engine Number*			

Manufacturers safety options – is the vehicle fitted with any of the following features?

<input type="checkbox"/> ESC (Electronic Stability Control)	<input type="checkbox"/> SRS (Supplementary Restraint System)	<input type="checkbox"/> EBS (Electronic Brake Distribution)
<input type="checkbox"/> ABS (Anti-lock Braking System)	<input type="checkbox"/> Other (Please specify) _____	

Adaptive hand/foot/electronic controls – driver training/specialised driving equipment

Adaptive hand/foot controls	Dual controls	Operation	Additional information
<input type="checkbox"/> Push/pull hand control	<input type="checkbox"/> Accelerator	<input type="checkbox"/> Cable	_____
<input type="checkbox"/> Spinner knob	<input type="checkbox"/> Brake	<input type="checkbox"/> Mechanical	_____
	<input type="checkbox"/> Clutch	<input type="checkbox"/> Hydraulic	_____
<input type="checkbox"/> Other		<input type="checkbox"/> Electronic	_____

Section 3 – Vehicle rating/category

(✓ as appropriate)	Original <input type="checkbox"/>	Unknown <input type="checkbox"/>	Proposed	
GVM				
ADR category				
Comments	_____ _____ _____			

Section 4 - Engine

(✓ as appropriate)	Original <input type="checkbox"/>	Unknown <input type="checkbox"/>	Proposed					
Capacity/Cylinders	ml	cyl	ml	cyl				
Make								
Year of manufacture								
Type (inline, v8, rotary)								
Fuel type								
Fuel induction (<i>circle</i>)	Naturally Aspirated	Turbo charged	Supercharged	Fuel injected	Naturally Aspirated	Turbo charged	Supercharged	Fuel injected
New engine number	N/A							
Engine weight (kg)								
Comments	_____ _____ _____							

Section 5 – Transmission

(✓ as appropriate)	Original <input type="checkbox"/>	Unknown <input type="checkbox"/>	Proposed	
Type				
Comments	_____ _____ _____			

Section 6 – Driveline

(✓ as appropriate)	Original <input type="checkbox"/>	Unknown <input type="checkbox"/>	Proposed	
Type				
Comments	_____ _____ _____			

Section 7 – Front axle and suspension

(✓ as appropriate)	Original <input type="checkbox"/>	Unknown <input type="checkbox"/>	Proposed	
Axle type				
Suspension Type				
Comments	_____ _____ _____			

Section 8 – Rear axle and suspension

(✓ as appropriate)	Original <input type="checkbox"/>	Unknown <input type="checkbox"/>	Proposed	
Axle type				
Suspension type				
Comments	_____ _____ _____			

Section 9 - Brakes

(✓ as appropriate)	Original <input type="checkbox"/>	Unknown <input type="checkbox"/>	Proposed	
Master cylinder make				
Type (circle)	Dual	Single	Dual	Single
Brake booster make				
Front brakes (circle)	Disc	Drum	Disc	Drum
Rear brakes (circle)	Disc	Drum	Disc	Drum
Handbrake type				
Proportioning valve				
Comments	_____ _____ _____			

Section 10 – Steering

(✓ as appropriate)	Original <input type="checkbox"/>		Proposed	
Type (circle)	Box	Rack	Box	Rack
Column				
Comments	_____ _____ _____			

Section 11 – Front wheels and tyres

(✓ as appropriate)	Original <input type="checkbox"/>	Unknown <input type="checkbox"/>	Proposed
Wheel diameter			
Rim width			
Rim offset (-neg/+pos)			
Tyre size/rating			
Comments	_____ _____ _____ _____		

Section 12 – Rear wheels and tyres

(✓ as appropriate)	Original <input type="checkbox"/>	Unknown <input type="checkbox"/>	Proposed
Wheel diameter			
Rim width			
Rim offset (-neg/+pos)			
Tyre size/rating			
Comments	_____ _____ _____ _____		

Wheel Rim Offset

Negative Offset

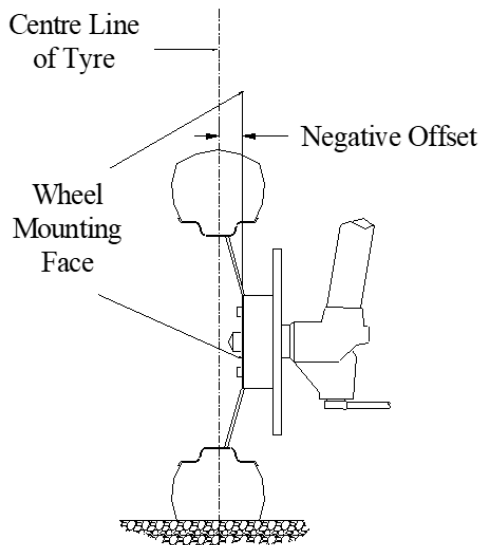

Positive Offset

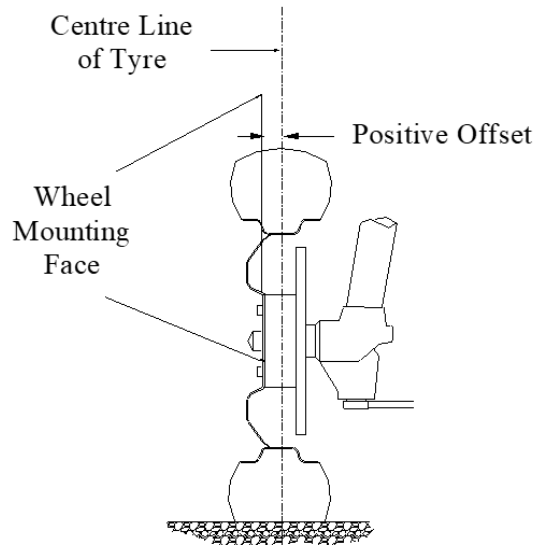

Section 13 – Wheel track

(✓ as appropriate)	Original <input type="checkbox"/>	Unknown <input type="checkbox"/>	Proposed
Front (mm)			
Rear (mm)			
Comments	<hr/> <hr/> <hr/> <hr/>		

Wheel track - Wheelbase - Overall height

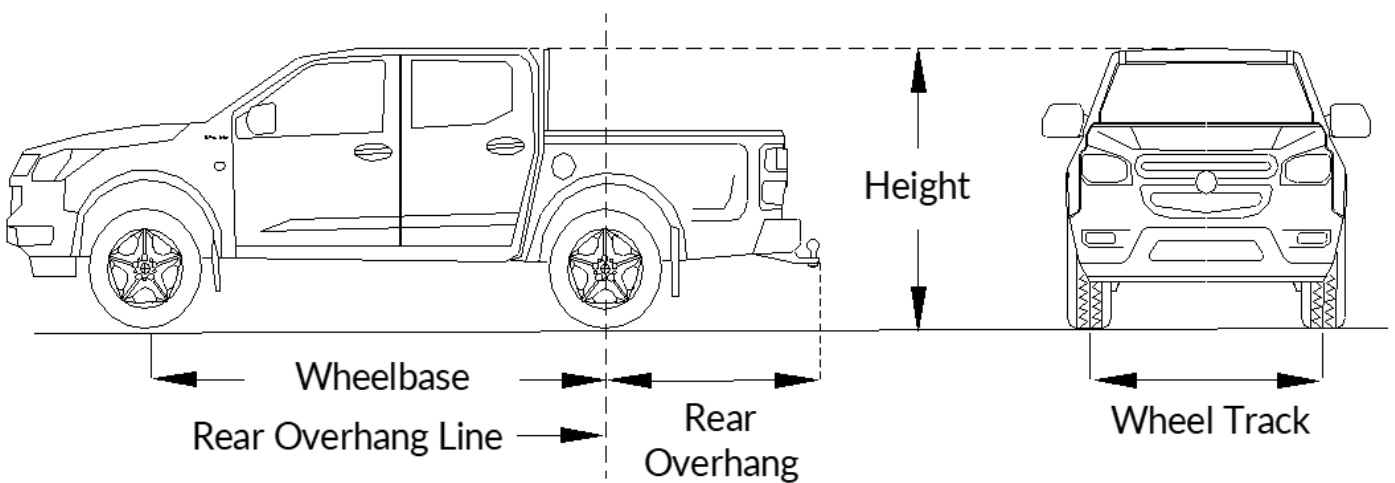

Note:

- Wheel Track is measured from the centre of the tyre to the centre of the opposite tyre on the same axle
- Wheelbase is measured from the centre of the front axle to the centre of the rear axle (rear overhang line)
- Rear Overhang is the distance measured from the rear overhang line to the rearmost part of the vehicle
- Overall height is measured from the ground to the highest rigid point of the roof (excluding vehicle accessories)
- Minimum ground clearance dimensions apply
- For further information on vehicle dimension limits including load, refer to Information Bulletin V13 Vehicle Dimension Limits - https://nt.gov.au/_data/assets/pdf_file/0007/374335/v13-vehicle-dimensional-limits.pdf

Section 14 – Wheelbase and overall height

(✓ as appropriate)	Original <input type="checkbox"/>	Unknown <input type="checkbox"/>	Proposed
Wheelbase (mm)			
Rear overhang (mm)			
Overall height (mm)			
Comments	<hr/> <hr/> <hr/> <hr/>		

Section 15 – Chassis and body

(✓ as appropriate) Details of proposed changes and materials	Original <input type="checkbox"/>	Unknown <input type="checkbox"/>	
		
		
		
		

Section 16 – Seating

(✓ as appropriate) Seat type (front) Seat manufacturer (front) Seat attachment method (front) Seat type (other) Seat manufacturer (other) Seat attachment method (other) Comments	Original <input type="checkbox"/>	Unknown <input type="checkbox"/>	Proposed
		

Section 17 – Seatbelts

(✓ as appropriate) Seat belt type (front) Seatbelt manufacturer (front) Seatbelt compliance /approvals (front) Seatbelt attachment method (front) Seatbelt type (other) Seatbelt manufacturer (other) Seatbelt compliance /approvals (other) Seatbelt attachment method (other) Comments	Original <input type="checkbox"/>	Unknown <input type="checkbox"/>	Proposed
		

Section 18 - Applicant declaration

*I/we,

.....
(name of vehicle owner/s)

of

.....
(address)

Solemnly and sincerely declare that:

- All information contained in this application is true and correct to the best of my/our knowledge by virtue of the *Oaths, Affidavits and Declarations Act 2010*; and
- I/we have read and understood the information contained in this application; and
- I/we am/are 18 years or older; and
- I/we know that it is an offence to make a declaration that is false in any material particular.

*This declaration is made at

.....
(location)

on

.....
(date)

.....
(applicant/s signature)

Note: Under the *Oaths, Affidavits and Declarations Act 2010* a person wilfully making a false statement or altering a statement in a statutory declaration is guilty of a crime and is liable to a penalty or imprisonment, or both.

Section 19 – Authorisation of representative

As the applicant/s, I/we hereby grant the following person authorisation to act on my/our behalf for the purpose of this application - “Contact person” to be noted on the front page of this application form.

.....
Name of authorised representative

.....
Signature of authorised representative

.....
Date

Section 20 – Submit application and enquiries

1. Email completed application form to vehiclestandards.mvr@nt.gov.au
2. Postal address – Vehicle Standards and Compliance Officer
Road Safety and Compliance - Department of Infrastructure, Planning and Logistics
PO Box 2520
Darwin NT 0801
3. Office address - Vehicle Standards and Compliance Officer
Road Safety and Compliance - Department of Infrastructure, Planning and Logistics
Level 2, Energy House
[18 - 20 Cavenagh Street](#)
Darwin NT 0800
4. Vehicle Standards and Compliance Officer - telephone (08) 8924 7157
5. Monthly meeting assessments of modified vehicle applications on first Wednesday of every month – except January
6. Applications received less than 7 days prior to monthly meeting will be deferred to next meeting
7. See “Notes for guidance” on form

Section 21 - Privacy statement

Privacy statement: The Registrar of Motor Vehicles is required to collect information for registrations, licenses and permits under section 92 of the NT *Motor Vehicles Act 1949*. The Registrar adheres to the department’s privacy statement and the *Information Act 2002*.

Further information on privacy can be found at www.dipl.nt.gov.au